

ERIKS SE

design
catalog

USA



The ERIKS USA Companies

ERIKS USA is part of the worldwide ERIKS group which has employees and facilities in Europe, the Middle East, Asia and of course the United States.



*ERIKS Southwest
Ft. Worth, TX*



*ERIKS West
Seattle, WA*



*ERIKS Midwest
New Berlin, WI*



*Turpen &
Associates
Tulsa, OK*

ERIKS is a global provider for a wide range of high quality engineered components, primarily related to Elastomer and Engineered plastic components used in critical applications and environments.

Here in the USA we have multiple locations to support our customers engineering design and product supply needs. The ERIKS SE product line is produced in our New Berlin, Wisconsin facility and stocked at our local operating companies.

Currently our USA locations are in;

Forth Worth, Texas

Tulsa, Oklahoma

Seattle, Washington

Anaheim, California

New Berlin, Wisconsin

Industry Applications

We service most of the major industries that require Advanced Engineering Products including, but not limited to;

- Aerospace
- Oil/Gas Equipment
- Semiconductor
- Medical
- Agriculture
- Construction Equipment



Introduction

Know-How Makes the Difference

Market know-how through strong customer relationships helps keep ERIKS on the forefront of industry needs. With a diverse and experienced technical staff ERIKS can aid in product selection as well as product development. This application know-how lets us be a partner not just a supplier. Being an international distribution company gives ERIKS a natural advantage in logistics know-how as we coordinate 60 operating companies in 13 countries. And finally our technical staff does much more than specify parts. They dig into the applications and offer solutions beyond the basic component level. This we call Product Processing know-how.



An Industrial Service Provider

Our group of technical distribution and manufacturing companies procures, stocks, processes, sells and delivers a wide range of high-quality engineered components. Through our E-Fab facility we also design and manufacture the products that make up the ERIKS SE product line. This product line consists primarily of spring energized seals but with our vast knowledge of engineered plastics we can also help in the development of many other types of component parts and assemblies. ERIKS is an innovative, progressive and flexible partner to its customers and through our know-how we can offer support on just about any level.

Table of Contents

Spring Energized Concept	page 4
Available Jacket Materials	page 5
Standard Seals - Cantilever Spring	page 6
Standard Seals - Spiral Pitch Spring	page 7
Standard Seals - Helical Spring	page 8
Special Configurations	page 9
Spring Selection	page 10
Spring Availability	page 11
Part Numbering System	page 12
Design Considerations - Surface Finish & Hardness Values	page 13
Design Considerations - Gland Styles	page 14
Troubleshooting Guide	page 15
Gland Dimensions - Rod & Piston Seals	page 16
Gland Dimensions - Internal Face Seals	page 18
Gland Dimensions - External Face Seals	page 20
Technical Action Request	page 22

Spring Energized Concept

ERIKS SE is the name given to the ERIKS brand of Spring Energized Seals. SE seals are designed to handle a wide range of applications where conventional elastomers may fail.

Applications including high-speeds, wide temperature ranges and/or corrosive media, all are areas where SE seals excel.

The SE design is based on three principles

1. High-Performance, Engineered Materials
2. U-Cup Style Seal Jackets
3. Metal Spring Energizers

The purpose of this design catalog is to, through careful consideration of these three parameters, aid in selecting the appropriate seal for a given application as well as help design the seal gland to ensure the best possible results.

PTFE and other polymer blends do not possess the same memory properties as conventional elastomers. As such, without proper support these materials will cold flow. To combat the cold flow issues, a metal spring energizer is used. As a result, spring energized seals use system pressure and spring energizers to create a positive seal.

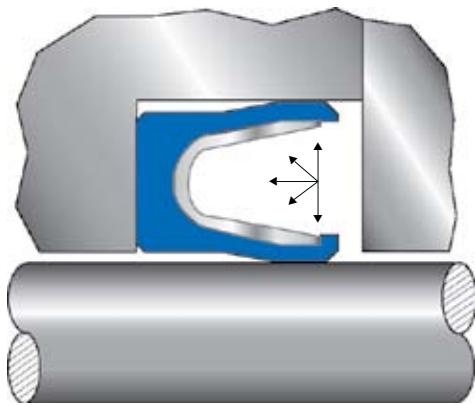
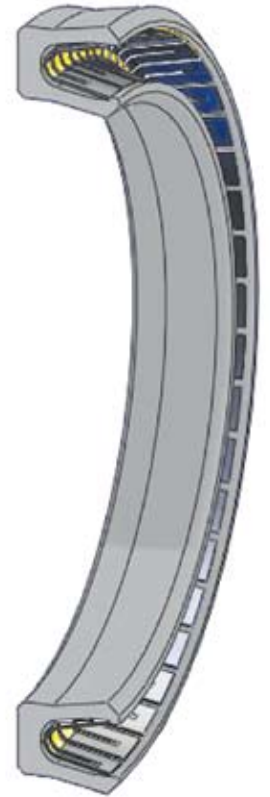

Below ~100 psi the spring provides the sealing force.

PRESSURE

Fig. 1

Figure 1 represents a low-pressure sealing situation where the system pressure alone does not provide enough force to seal. The spring in this situation provides the necessary sealing force. Below approximately 100 psi the spring energizer supplies the internal force to create a positive seal.

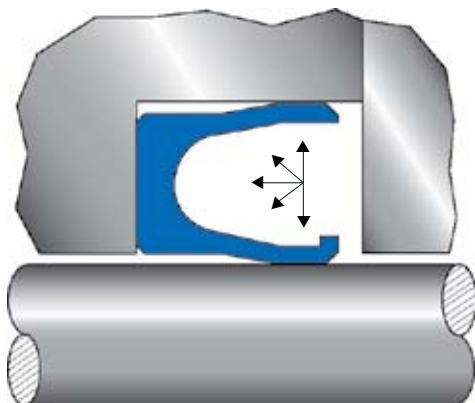

Above ~100 psi system pressure provides the sealing force.

PRESSURE

Fig. 2

Figure 2 represents a higher pressure application where system pressure is sufficient to create a positive seal. This threshold occurs at approximately 100 psi allowing system pressure to take over and provide the sealing force.

Available Jacket Materials*

Material Code	Description	Typical Applications	Temperature Range	Coefficient of Friction
E400	Virgin PTFE Color: White	An FDA compliant, light duty material. Good in light gases and cryogenic service.	-400 to +450	.05 / .08
E471	Graphite Filled PTFE Color: Black	The graphite filler in this blend acts as a dry lubricant making it a good choice in dry running services.	-320 to +475	.06 / .10
E431	Glass/Moly Filled PTFE Color: Dark Gray	A highly wear resistant blend good for high speed applications on hardened shafts.	-250 to +550	.06 / .10
E462	Carbon/Graphite Filled PTFE Color: Dark Gray	A good material choice for combinations of speed and temperature.	-320 to +475	.08 / .12
E491	Ekonol Filled PTFE Color: Beige	This blend uses a non-abrasive polymer filler. Best in dynamic applications running against soft metals.	-200 to +550	.08 / .12
E282Z	Carbon/Graphite/PPS Filled PTFE Color: Black	Heavy duty material reserved for the most difficult combinations of temperature, speed and pressure.	-200 to +550	.08 / .12
E220	Thermoplastic Elastomer Color: Black	When corrosion resistance and temperature extremes are not the primary concerns TPE is a good choice for tight sealing.	-80 to +275	.30 / .60
E010	UHMW-PE Color: Translucent White	An FDA compliant material with very good wear resistance.	-320 to +200	.15 / .25
E020	Acetal Color: Brown	As a backup ring this material has good extrusion resistance with low water absorption.	-70 to +250	.30 / .40
E125	PEEK Color: Tan	A high-modulus, engineered plastic with excellent thermal and mechanical properties.	-100 to +550	.35 / .45





*Not all materials shown. Consult factory for additional materials.

Standard Seals - Cantilever Spring

Section View	Description	Part # Code*	Pressure Rating	Application
	Standard Lip Standard Heel	EV1A EV2A	3,000 psig	A good general purpose solution. The EV1A and EV2A series are designed for slow to moderate speeds over a wide temperature and pressure range.
	I.D. Scraper Standard Heel	EV1B EV2B	3,000 psig	Used in reciprocating rod applications with viscous fluids. The scraper lip can also be used to “snap” the seal into stepped glands.
	O.D. Scraper Standard Heel	EV1C EV2C	3,000 psig	Used in reciprocating piston applications with viscous fluids. The scraper lip can also be used to “snap” the seal into stepped glands.
	Double Scraper Standard Heel	EV1D EV2D	3,000 psig	Good for the combination of a stepped gland and reciprocating motion.
	Standard Lip Extended Heel	EV3A EV4A	10,000 psig	Same as EV1A and EV2A series but with greater pressure capabilities.
	I.D. Scraper Extended Heel	EV3B EV4B	10,000 psig	Same as EV1B and EV2B series but with greater pressure capabilities.
	O.D. Scraper Extended Heel	EV3C EV4C	10,000 psig	Same as EV1C and EV2C series but with greater pressure capabilities.
	Double Scraper Extended Heel	EV3D EV4D	10,000 psig	Same as EV1D and EV2D series but with greater pressure capabilities.
	Internal Face Seal	EV5A	3,000 psig	An excellent alternative to elastomers in applications with difficult combinations of temperature and pressure and little to no motion. The EV5A seals pressure from an internal source.
	External Face Seal	EV6A	3,000 psig	An excellent alternative to elastomers in applications with difficult combinations of temperature and pressure and little to no motion. The EV6A seals pressure from an external source.





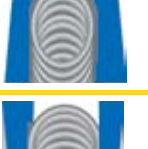





*For full part number description see pg. 12

Standard Seals - Spiral Pitch Spring

Section View	Description	Part # Code*	Pressure Rating	Application
	Standard Lip Standard Heel	ES1A ES2A	3,000 psig	The ES1A and ES2A series are designed for higher speed applications where a constant spring force is of benefit. Temperatures are limited to 300° F.
	I.D. Scraper Standard Heel	ES1B ES2B	3,000 psig	Used in reciprocating rod applications with viscous fluids. The scraper lip can also be used to “snap” the seal into stepped glands.
	O.D. Scraper Standard Heel	ES1C ES2C	3,000 psig	Used in reciprocating piston applications with viscous fluids. The scraper lip can also be used to “snap” the seal into stepped glands.
	Double Scraper Standard Heel	ES1D ES2D	3,000 psig	Good for the combination of a stepped gland and reciprocating motion.
	Standard Lip Extended Heel	ES3A ES4A	10,000 psig	Same as ES1A and ES2A series but with greater pressure capabilities.
	I.D. Scraper Extended Heel	ES3B ES4B	10,000 psig	Same as ES1B and ES2B series but with greater pressure capabilities.
	O.D. Scraper Extended Heel	ES3C ES4C	10,000 psig	Same as ES1C and ES2C series but with greater pressure capabilities.
	Double Scraper Extended Heel	ES3D ES4D	10,000 psig	Same as ES1D and ES2D series but with greater pressure capabilities.
	Internal Face Seal	ES5A	3,000 psig	An excellent alternative to elastomers in applications with difficult combinations of temperature, pressure and speed. The ES5A seals pressure from an internal source.
	External Face Seal	ES6A	3,000 psig	An excellent alternative to elastomers in applications with difficult combinations of temperature, pressure and speed. The ES6A seals pressure from an external source.







*For full part number description see pg. 12

Standard Seals - Helical Spring

Section View	Description	Part # Code*	Pressure Rating	Application
	Standard Lip Standard Heel	EH1A EH2A	3,000 psig	The EH1A and EH2A series are best suited for very slow or static applications where tight sealing in light fluids and gases is important. Also a very good choice for low pressure applications.
	I.D. Scraper Standard Heel	EH1B EH2B	3,000 psig	Used in reciprocating rod applications with viscous fluids. The scraper lip can also be used to "snap" the seal into stepped glands.
	O.D. Scraper Standard Heel	EH1C EH2C	3,000 psig	Used in reciprocating piston applications with viscous fluids. The scraper lip can also be used to "snap" the seal into stepped glands.
	Double Scraper Standard Heel	EH1D EH2D	3,000 psig	Good for the combination of a stepped gland and reciprocating motion.
	Standard Lip Extended Heel	EH3A EH4A	10,000 psig	Same as EH1A and EH2A series but with greater pressure capabilities.
	I.D. Scraper Extended Heel	EH3B EH4B	10,000 psig	Same as EH1B and EH2B series but with greater pressure capabilities.
	O.D. Scraper Extended Heel	EH3C EH4C	10,000 psig	Same as EH1C and EH2C series but with greater pressure capabilities.
	Double Scraper Extended Heel	EH3D EH4D	10,000 psig	Same as EH1D and EH2D series but with greater pressure capabilities.
	Internal Face Seal	EH5A	3,000 psig	An excellent alternative to elastomers in applications with difficult combinations of temperature and pressure and little to no motion. The EH5A series seals pressure from an internal source.
	External Face Seal	EH6A	3,000 psig	An excellent alternative to elastomers in applications with difficult combinations of temperature and pressure and little to no motion. The EH6A series seals pressure from an external source.

*For full part number description see pg. 12

Special Configurations*

Section View	Description	Product Code	Pressure Rating	Application
	High-Speed Rotary Lip Seal	EX7	250 psig	The EX7 series is a low cost, all polymer lip seal. There is no spring energizer as the sealing lip is formed instead of machined yielding low contact forces and running friction.
	Single Contact Anti-Rotation Seal	EV8	3,000 psig	The EV8 series uses a standard cantilever spring loaded U-cup for the I.D. seal but on the O.D. an O-ring is used for the static seal and the anti-rotation mechanism.
	Single Contact Anti-Rotation Seal	ES8	3,000 psig	Similar to the EV8 series but with a spiral pitch spring instead of a cantilever spring. Constant spring force and greater dimensional variances can be handled with this configuration.
	Double Contact Anti-Rotation Seal	EV9	2,000 psig	Similar to the EV8 series but with a contacting lip on both the O.D. and the I.D. as well as an O-ring for anti-rotation. A good choice for smaller cross sections.
	Double Contact Anti-Rotation Seal	ES9	2,000 psig	Same configuration as the EV9 but with spiral pitch spring instead of cantilever spring. The ES9 can handle higher speeds and greater dimensional variances.
	Silicone Filled Spring Groove	EVS	Up to 10,000 psig	Used primarily in food and drug applications, silicone fills the spring cavity to prevent entrapment of biological contaminants. Also effective for preventing the seal groove from becoming packed with viscous or solidifying fluids. Only available with cantilever spring.
	Tandem Springs	EXT	Up to 10,000 psig	By dividing the seal into two separate seal cavities, much larger hardware cross sections can be accommodated. Available in all three spring types.
	Nested Springs	EVN	Up to 10,000 psig	By placing one spring inside another (nesting) greater spring force can be established. This configuration is especially effective in cryogenic services or applications where a high unit load is required. Available with cantilever spring only.
	O-Ring Energizers	EXO	Up to 10,000 psig	For applications that require no metal contact with the process fluid an O-ring energizer can be used. Energizers are available in most elastomeric materials to suit the application.
	Flanged Rotary Seal	EXF	Up to 3,000 psig	An anti-rotation design for high-speed rotary applications. Special hardware design modifications are required. Consult factory for specifics. Available with cantilever and spiral pitch springs.
	Backup Rings	EBR	Up to 30,000 psig	For use in extreme pressure situations or when the extrusion gap is larger than recommended. Backup rings can be configured several different ways to suit an application. Consult the factory for specifications.

*Special configurations are not available as standard dash numbers. Contact factory for sizing.

Spring Selection

When considering a spring energized seal, the spring choice can be very important. Through the spring the seal can be “fine tuned” for each individual application. For example, if an application requires tight sealing of light gases in a static environment then the helical spring may be a good choice.

Likewise, if an application requires constant force over the useable life of the seal in a dynamic environment then perhaps the spiral pitch spring is the right choice. Once the spring type is selected, in some cases there is additional variability with the spring load.

The graph below describes typical loading forces of the three different spring types. Please consult the factory for specific spring forces per series.

Typical Load vs. Deflection Curves*

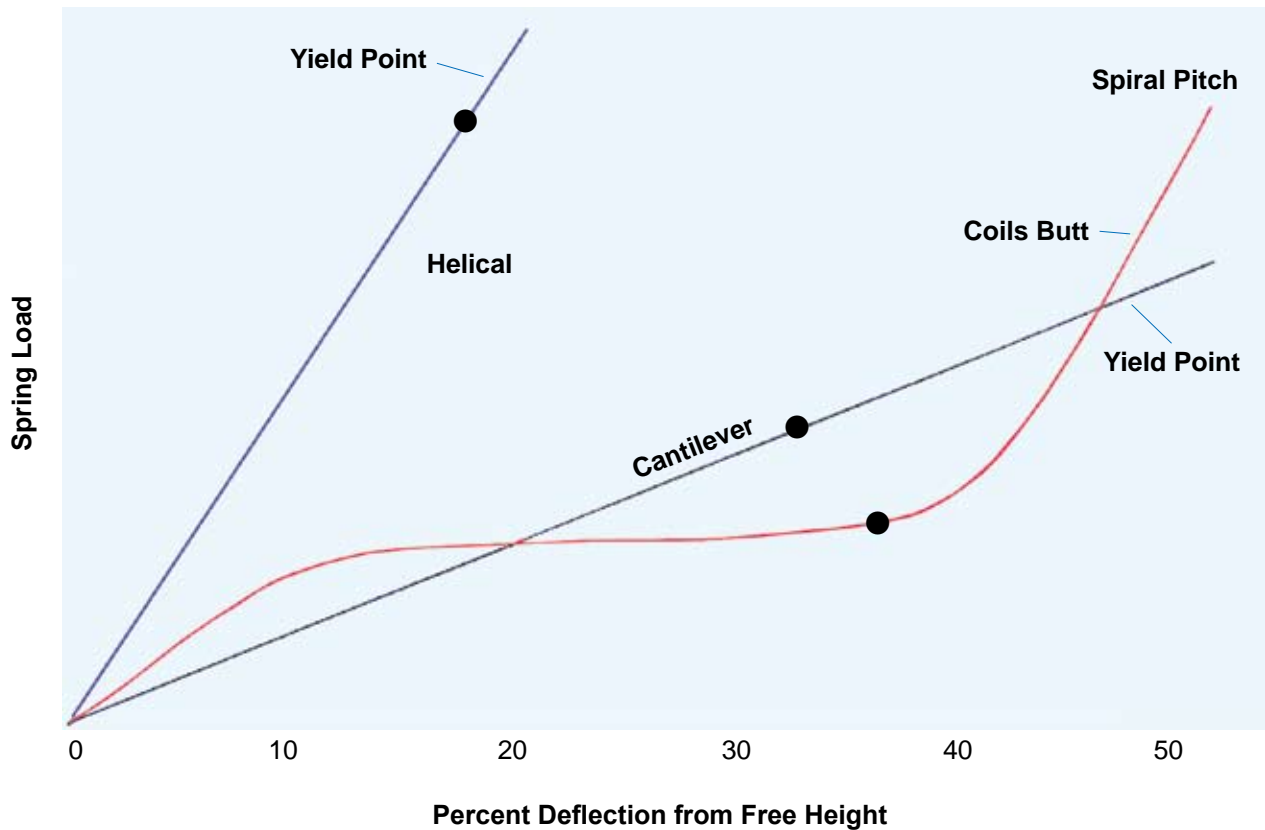

● = load point for each spring type.

Cantilever spring, commonly referred to as V-spring or finger spring has a shallow but linearly rising load curve. As a result force will decrease as the seal wears. The load curve for the **Spiral Pitch** spring is non-linear which allows the force to remain constant over the life of the seal. **Helical** spring is also linearly rising but at a much steeper slope. This means that force falls off rapidly with seal wear but high until loading is achievable in the static state.



*Graph not necessarily representative of any one spring.

Spring Availability

Spring Type	Material Code	Material Description	Standard	Optional
Cantilever	1	301 Stainless Steel	✓	
	6	316 Stainless Steel		✓
	H	Hastelloy® C-276		✓
	E	Elgiloy®		✓
Spiral Pitch	2	302 Stainless Steel	✓	
	6	316 Stainless Steel		✓
	H	Hastelloy® C-276		✓
Helical	2	302 Stainless Steel	✓	
	H	Hastelloy® C-276		✓

Hastelloy is a registered trademark of Haynes Int'l.

Elgiloy is a registered trademark of Elgiloy Limited Partnership

Minimum I.D. Per Spring Type

Series	Minimum Seal I.D.		
	Cantilever	Spiral Pitch	Helical
000	0.125	0.062	0.125
100	0.187	0.125	0.187
200	0.500	0.250	0.250
300	0.750	0.500	0.500
400	1.250	0.750	1.000

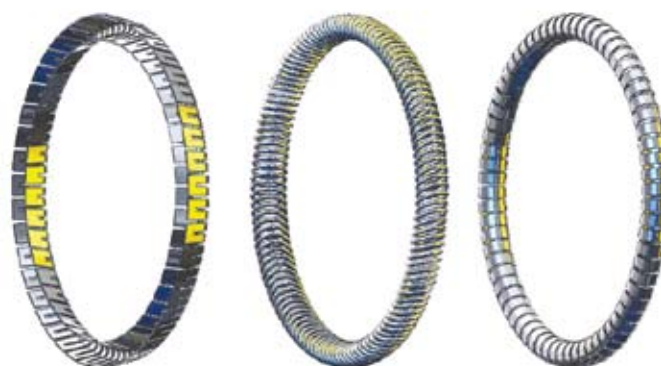

Cantilever

Spiral Pitch

Helical

Spring Loads

Spring Type	Load	Series				
		000	100	200	300	400
Cantilever	Light	X	X	X	X	X
	Medium	✓	✓	✓	✓	✓
	Heavy	X	X	X	X	X
Spiral Pitch	Light	✓	✓	✓	✓	✓
	Medium	✓	✓	✓	✓	✓
	Heavy	✓	✓	✓	✓	✓
Helical	Light	X	X	X	X	X
	Medium	X	X	X	X	X
	Heavy	✓	✓	✓	✓	✓

✓ = Available X = Not Available

Part Numbering System - Rod & Piston Seals

E	V	1	A	—	1	M	—	136	—	010
Product Line	Spring Type	Seal Type	Lip Configuration	Spring Material	Spring Load	Dash Number	Material Code			
ERIKS SE	V=Cantilever	1=Standard Heel Rod Seal	A=Standard	1=301 SS See page 11 for Available Spring Materials	L=Light	See pages 16-17	See page 5			
	S=Spiral Pitch		B=I.D. Scraper		M=Medium					
	H=Helical	2=Standard Heel Piston Seal	C=O.D. Scraper		H=Heavy					
		3=Extended Heel Rod Seal	D=Double Scraper							
		4=Extended Heel Piston Seal								

Part Numbering System - Face Seals

E	H	5	A	—	2	M	—	139	—	5
Product Line	Spring Type	Seal Type	Lip Configuration	Spring Material	Spring Load	Dash Number	Material Code			
ERIKS SE	V=Cantilever	5=Internal Face Seal	A=Standard for all Face Seals	2=203 SS See page 11 for Available Spring Materials	L=Light	See pages 18-21	See page 5			
	S=Spiral Pitch				M=Medium					
	H=Helical	6=External Face Seal			H=Heavy					

Design Considerations - Surface Finish

One of the most important factors for seal performance is surface finish. This is certainly true for conventional elastomers but it is critical for PTFE spring energized seals. Though an improper finish may not cause complete seal failure, it is likely to yield inconsistent performance from one assembly to the next. The required surface finish is also a result of the media being sealed. Figure 3 lists general guidelines for surface finish with respect to spring energized seals.



Recommended Surface Finish

Media to Seal	Dynamic Surface	Static Surface
Cryogenics (Helium, Hydrogen)	2-8 μ inch RMS	8-12 μ inch RMS
Gases (Air, Nitrogen, Oxygen, Natural Gas, etc.)	6-12 μ inch RMS	12-20 μ inch RMS
Liquids (Hydraulic Fluid, Water, Crude Oil)	8-16 μ inch RMS	16-32 μ inch RMS

Fig. 3

Design Considerations - Surface Hardness

Equally important to surface finish with PTFE spring energized seals is surface hardness, particularly in dynamic applications. Over time a highly filled PTFE blend can wear a groove into as-machined stainless steel at the point of contact. Once this occurs, leakage is eminent and motion within the working system can be obstructed. Figure 4 gives general recommendations for surface hardness with respect to application speed and pressure.



Recommended Hardness Values

Type of Motion	Surface Speed (sfpm)	Hardness Rockwell C				
		0 psi	150	500	1000	5000+
Reciprocating	Up to 100	30	30	35	40	50
	100 and Over	44	44	48	50	60
Rotary	Up to 150	44	50	55	70	70+
	150 to 500	60	65	70	70+	*
	500 to 2500+	65	70	70+	*	*

Fig. 4

*Consult factory

Design Considerations - Gland Styles

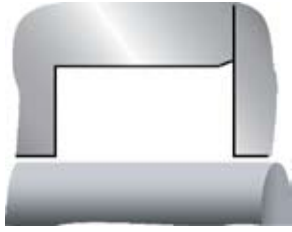

Split Rod

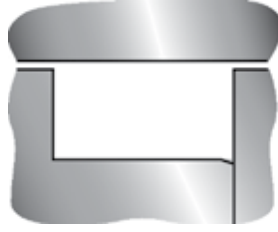

Split Piston

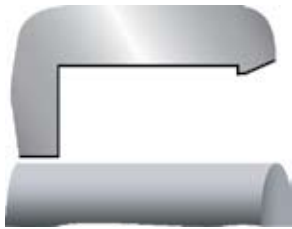

Stepped Rod

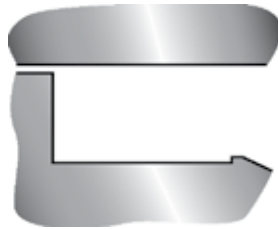

Stepped Piston

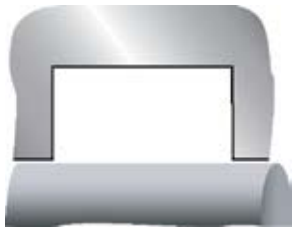

Solid Rod

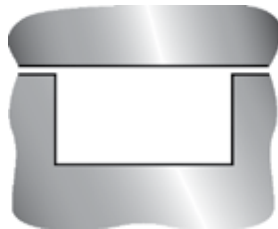

Solid Piston

Gland Options

Because PTFE does not act like a conventional elastomer, special consideration must be taken when designing the seal gland. Earlier in this catalog surface finish and hardness were discussed. The third critical aspect to a successful ERIKS SE sealing solution is gland geometry.

Split Gland

Ideally for SE products a split or 2-piece gland is desirable. This configuration allows for easy installation of any type of seal. When a split gland is not practical, one of the following options can be employed.

Stepped Gland

Stepped glands can be used with either rod or piston seals. A scraper lip on the seal is recommended for retaining the seal.

Solid Gland

Though it is possible to install an ERIKS SE seal into a solid gland, certain size restrictions apply. Contact the factory for solid gland limitations.

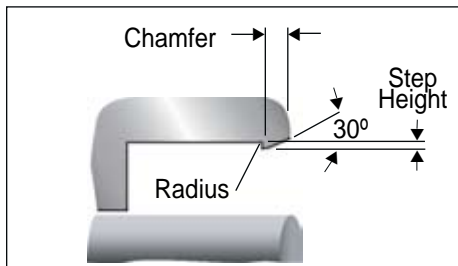

Stepped Rod Gland Dimensions

Series	Step Height	Max. Radius	Min. Chamfer	Min. Seal ID
000	.008/.012	.005	.025	.250
100	.010/.015	.005	.030	.375
200	.015/.020	.007	.040	.750
300	.017/.023	.010	.045	1.000
400	.022/.028	.010	.055	2.000

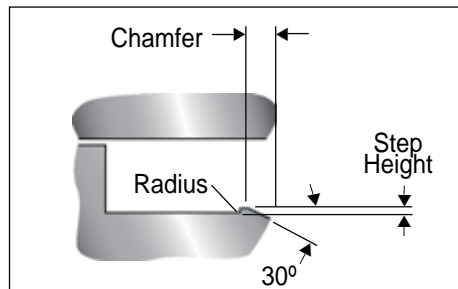

Stepped Piston Gland Dimensions

Series	Step Height	Max. Radius	Min. Chamfer	Min. Seal ID
000	.008/.012	.005	.025	.375
100	.010/.015	.005	.030	.563
200	.015/.020	.007	.040	1.000
300	.017/.023	.010	.045	1.375
400	.022/.028	.010	.055	2.500

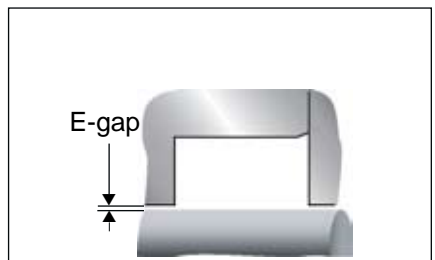

Maximum Extrusion Gap.

Series	300 psi	1500 psi	3000 psi	6000 psi
000	.008	.004	.003	.002
100	.010	.006	.004	.003
200	.014	.008	.006	.003
300	.020	.010	.008	.004
400	.024	.012	.010	.005

Troubleshooting Guide

Symptom		Cause											
		Normal Wear	Normal Wear High-Pressure	Yielded Spring or Poor Weld	Misalignment or Poor Weld	Improper Support or Runout	Rough Mating Surfaces	Improper Surface Hardness	System Pressure Too High	Machining or Handling Issue	Chemical Compatibility	Installation Damage	
Seal Trouble Indicators	An even, glossy circumferential pattern on the dynamic lip	●											
	A large, even circumferential pattern on the dynamic lip		●						●				
	An even pattern with one highly worn spot			●	●								
	A heavy wear pattern on one side of the seal			●	●								
	A combination of high and low wear spots			●	●							●	
	Radial grooving with embedded metal filings						●	●				●	
	Axial nicks on seal lips						●					●	
	Cracks or holes in the seal jacket					●			●		●	●	
	Small protrusion on heel of seal at E-gap	●	●										
	Large protrusion on heel of seal at E-gap		●						●				
	Separation between spring groove and spring			●								●	
	Missing spring tabs				●							●	
Hardware Trouble Indicators	Even, glossy circumferential area on the hardware	●											
	Large, even glossy circumferential area on the hardware		●						●				
	Axial scratches on dynamic surface						●	●				●	
	Nicks or burrs on sealing location or installation path								●				
	An offset wear pattern				●								
	Pitting or corrosion									●			
	Keyways, splines, threads or holes											●	
Circumferential grooving of the dynamic surface		●						●	●		●		

Gland Dimensions - Rod & Piston Seals

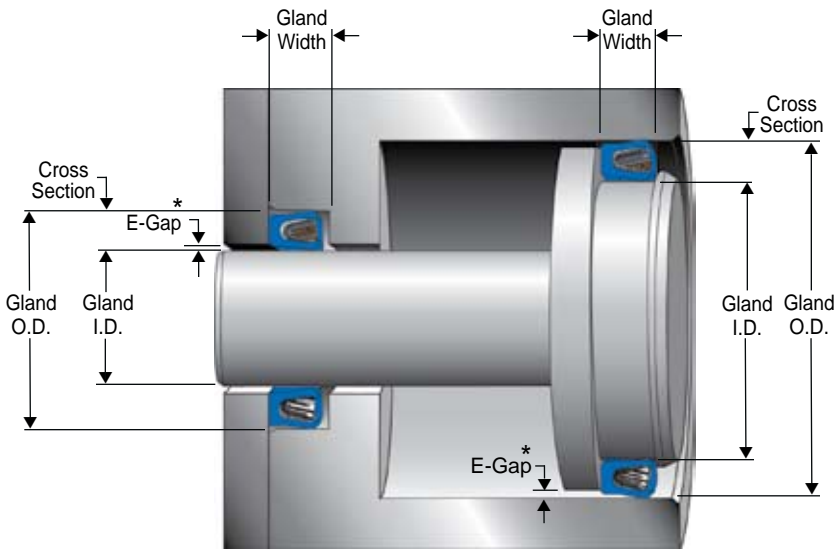

Gland Tolerances

Seal I.D.	Gland I.D.	Gland O.D.
0.125 -	+0.000	+0.001
0.374	-0.001	-0.000
0.375 -	+0.000	+0.002
2.999	-0.002	-0.000
3.000 -	+0.000	+0.003
7.999	-0.003	-0.000
8.000	+0.000	+0.004
and Up	-0.004	-0.000

Series	Standard Width	Extended Width	Cross Section
-000	.094-.104	.149-.159	.062
-100	.141-.151	.183-.193	.094
-200	.188-.198	.235-.245	.125
-300	.281-.291	.334-.344	.187
-400	.375-.385	.475-.485	.250

000 Series

Dash Size	Gland I.D.	Gland O.D.	Dash Size	Gland I.D.	Gland O.D.	Dash Size	Gland I.D.	Gland O.D.	Dash Size	Gland I.D.	Gland O.D.
-006	0.125	0.250	-016	0.625	0.750	-026	1.250	1.375	-036	2.375	2.500
-007	0.156	0.281	-017	0.687	0.812	-027	1.312	1.437	-037	2.500	2.625
-008	0.187	0.312	-018	0.750	0.875	-028	1.375	1.500	-038	2.625	2.750
-009	0.218	0.343	-019	0.812	0.937	-029	1.500	1.625	-039	2.750	2.875
-010	0.250	0.375	-020	0.875	1.000	-030	1.625	1.750	-040	2.875	3.000
-011	0.312	0.437	-021	0.937	1.062	-031	1.750	1.875	-041	3.000	3.125
-012	0.375	0.500	-022	1.000	1.125	-032	1.875	2.000	-042	3.250	3.375
-013	0.437	0.562	-023	1.062	1.187	-033	2.000	2.125	-043	3.500	3.625
-014	0.500	0.625	-024	1.125	1.250	-034	2.125	2.250	-044	3.750	3.875
-015	0.562	0.687	-025	1.187	1.312	-035	2.250	2.375	-045	4.000	4.125

100 Series

Dash Size	Gland I.D.	Gland O.D.	Dash Size	Gland I.D.	Gland O.D.	Dash Size	Gland I.D.	Gland O.D.	Dash Size	Gland I.D.	Gland O.D.
-106	0.187	0.375	-120	1.000	1.187	-134	1.875	2.062	-148	2.750	2.937
-107	0.219	0.406	-121	1.062	1.250	-135	1.937	2.125	-149	2.812	3.000
-108	0.250	0.437	-122	1.125	1.312	-136	2.000	2.187	-150	2.875	3.062
-109	0.312	0.500	-123	1.187	1.375	-137	2.062	2.250	-151	3.000	3.187
-110	0.375	0.562	-124	1.250	1.437	-138	2.125	2.312	-152	3.250	3.437
-111	0.437	0.625	-125	1.312	1.500	-139	2.187	2.375	-153	3.500	3.687
-112	0.500	0.687	-126	1.375	1.562	-140	2.250	2.437	-154	3.750	3.937
-113	0.562	0.750	-127	1.437	1.625	-141	2.312	2.500	-155	4.000	4.187
-114	0.625	0.812	-128	1.500	1.687	-142	2.375	2.562	-156	4.250	4.437
-115	0.687	0.875	-129	1.562	1.750	-143	2.437	2.625	-157	4.500	4.687
-116	0.750	0.937	-130	1.625	1.812	-144	2.500	2.687	-158	4.750	4.937
-117	0.812	1.000	-131	1.687	1.875	-145	2.562	2.750	-159	5.000	5.187
-118	0.875	1.062	-132	1.750	1.937	-146	2.625	2.812	-160	5.250	5.437
-119	0.937	1.125	-133	1.812	2.000	-147	2.687	2.875	-161	5.500	5.687

Not all of the standard dash numbers are listed. For additional sizes, consult the factory. * See page 14 for E-gap recommendations

Gland Dimensions - Rod & Piston Seals

200 Series

Dash Size	Gland I.D.	Gland O.D.	Dash Size	Gland I.D.	Gland O.D.	Dash Size	Gland I.D.	Gland O.D.	Dash Size	Gland I.D.	Gland O.D.
-206	0.500	0.750	-220	1.375	1.625	-234	3.000	3.250	-248	4.750	5.000
-207	0.562	0.812	-221	1.437	1.687	-235	3.125	3.375	-249	4.875	5.125
-208	0.625	0.875	-222	1.500	1.750	-236	3.250	3.500	-250	5.000	5.250
-209	0.687	0.937	-223	1.625	1.875	-237	3.375	3.625	-252	5.250	5.500
-210	0.750	1.000	-224	1.750	2.000	-238	3.500	3.750	-254	5.500	5.750
-211	0.812	1.062	-225	1.875	2.125	-239	3.625	3.875	-256	5.750	6.000
-212	0.875	1.125	-226	2.000	2.250	-240	3.750	4.000	-258	6.000	6.250
-213	0.937	1.187	-227	2.125	2.375	-241	3.875	4.125	-260	6.500	6.750
-214	1.000	1.250	-228	2.250	2.500	-242	4.000	4.250	-262	7.000	7.250
-215	1.062	1.312	-229	2.375	2.625	-243	4.125	4.375	-264	7.500	7.750
-216	1.125	1.375	-230	2.500	2.750	-244	4.250	4.500	-266	8.000	8.250
-217	1.187	1.437	-231	2.625	2.875	-245	4.375	4.625	-268	8.500	8.750
-218	1.250	1.500	-232	2.750	3.000	-246	4.500	4.750	-270	9.000	9.250
-219	1.312	1.562	-233	2.875	3.125	-247	4.625	4.875			

300 Series

Dash Size	Gland I.D.	Gland O.D.	Dash Size	Gland I.D.	Gland O.D.	Dash Size	Gland I.D.	Gland O.D.	Dash Size	Gland I.D.	Gland O.D.
-316	0.875	1.250	-330	2.125	2.500	-344	3.875	4.250	-358	5.625	6.000
-317	0.937	1.312	-331	2.250	2.625	-345	4.000	4.375	-359	5.750	6.125
-318	1.000	1.375	-332	2.375	2.750	-346	4.125	4.500	-360	5.875	6.250
-319	1.062	1.437	-333	2.500	2.875	-347	4.250	4.625	-361	6.000	6.375
-320	1.125	1.500	-334	2.625	3.000	-348	4.375	4.750	-362	6.250	6.625
-321	1.187	1.562	-335	2.750	3.125	-349	4.500	4.875	-363	6.500	6.875
-322	1.250	1.625	-336	2.875	3.250	-350	4.625	5.000	-365	7.000	7.375
-323	1.312	1.687	-337	3.000	3.375	-351	4.750	5.125	-367	7.500	7.875
-324	1.375	1.750	-338	3.125	3.500	-352	4.875	5.250	-369	8.000	8.375
-325	1.500	1.875	-339	3.250	3.625	-353	5.000	5.375	-371	8.500	8.875
-326	1.625	2.000	-340	3.375	3.750	-354	5.125	5.500	-373	9.000	9.375
-327	1.750	2.125	-341	3.500	3.875	-355	5.250	5.625	-375	9.500	9.875
-328	1.875	2.250	-342	3.625	4.000	-356	5.375	5.750			
-329	2.000	2.375	-343	3.750	4.125	-357	5.500	5.875			

400 Series

Dash Size	Gland I.D.	Gland O.D.	Dash Size	Gland I.D.	Gland O.D.	Dash Size	Gland I.D.	Gland O.D.	Dash Size	Gland I.D.	Gland O.D.
-401	1.500	2.000	-413	3.000	3.500	-425	4.500	5.000	-437	6.000	6.500
-402	1.625	2.125	-414	3.125	3.625	-426	4.625	5.125	-438	6.250	6.750
-403	1.750	2.250	-415	3.250	3.750	-427	4.750	5.250	-439	6.500	7.000
-404	1.875	2.375	-416	3.375	3.875	-428	4.875	5.375	-440	6.750	7.250
-405	2.000	2.500	-417	3.500	4.000	-429	5.000	5.500	-441	7.000	7.500
-406	2.125	2.625	-418	3.625	4.125	-430	5.125	5.625	-442	7.250	7.750
-407	2.250	2.750	-419	3.750	4.250	-431	5.250	5.750	-443	7.500	8.000
-408	2.375	2.875	-420	3.875	4.375	-432	5.375	5.875	-444	7.750	8.250
-409	2.500	3.000	-421	4.000	4.500	-433	5.500	6.000	-445	8.000	8.500
-410	2.625	3.125	-422	4.125	4.625	-434	5.625	6.125	-446	8.500	9.000
-411	2.750	3.250	-423	4.250	4.750	-435	5.750	6.250	-447	9.000	9.500
-412	2.875	3.375	-424	4.375	4.875	-436	5.875	6.375	-448	9.500	10.000

Not all of the standard dash numbers are listed. For additional sizes consult the factory.

Gland Dimensions - Internal Face Seals

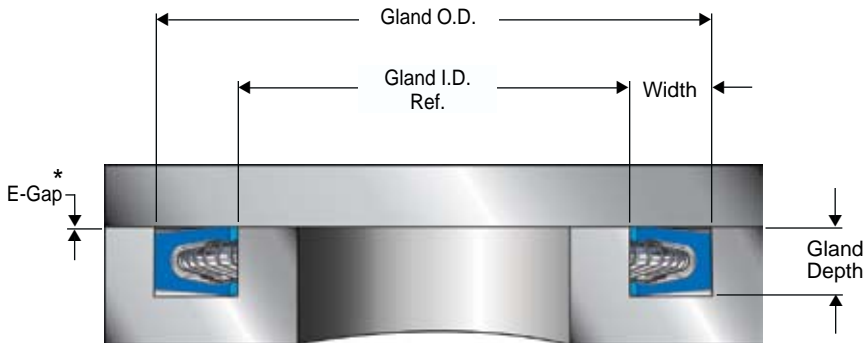

Gland Tolerances

Gland O.D.	Tolerance
0.500 - 2.999	+ .002 - .000
3.000 - 7.999	+ .003 - .000
8.000 and Up	+ .004 - .000

Series	Width Min.	Gland Depth
-000	.094	.057 - .059
-100	.141	.089 - .091
-200	.188	.121 - .123
-300	.281	.186 - .188
-400	.375	.238 - .241

000 Series

Dash Size	Gland I.D.	Gland O.D.	Dash Size	Gland I.D.	Gland O.D.	Dash Size	Gland I.D.	Gland O.D.	Dash Size	Gland I.D.	Gland O.D.
-012	0.312	0.500	-022	0.937	1.125	-032	1.812	2.000	-042	3.187	3.375
-013	0.375	0.562	-023	1.000	1.187	-033	1.937	2.125	-043	3.437	3.625
-014	0.437	0.625	-024	1.062	1.250	-034	2.062	2.250	-044	3.687	3.875
-015	0.500	0.687	-025	1.125	1.312	-035	2.187	2.375	-045	3.937	4.125
-016	0.562	0.750	-026	1.187	1.375	-036	2.312	2.500			
-017	0.625	0.812	-027	1.250	1.437	-037	2.437	2.625			
-018	0.687	0.875	-028	1.312	1.500	-038	2.562	2.750			
-019	0.750	0.937	-029	1.437	1.625	-039	2.687	2.875			
-020	0.812	1.000	-030	1.562	1.750	-040	2.812	3.000			
-021	0.875	1.062	-031	1.687	1.875	-041	2.937	3.125			

100 Series

Dash Size	Gland I.D.	Gland O.D.	Dash Size	Gland I.D.	Gland O.D.	Dash Size	Gland I.D.	Gland O.D.	Dash Size	Gland I.D.	Gland O.D.
-112	0.405	0.687	-126	1.280	1.562	-140	2.155	2.437	-154	3.655	3.937
-113	0.468	0.750	-127	1.343	1.625	-141	2.218	2.500	-155	3.905	4.187
-114	0.530	0.812	-128	1.405	1.687	-142	2.280	2.562	-156	4.155	4.437
-115	0.593	0.875	-129	1.468	1.750	-143	2.343	2.625	-157	4.405	4.687
-116	0.655	0.937	-130	1.530	1.812	-144	2.405	2.687	-158	4.655	4.937
-117	0.718	1.000	-131	1.593	1.875	-145	2.468	2.750	-159	4.905	5.187
-118	0.780	1.062	-132	1.655	1.937	-146	2.530	2.812	-160	5.155	5.437
-119	0.843	1.125	-133	1.718	2.000	-147	2.593	2.875	-161	5.405	5.687
-120	0.905	1.187	-134	1.780	2.062	-148	2.655	2.937	-162	5.655	5.937
-121	0.968	1.250	-135	1.843	2.125	-149	2.718	3.000	-163	5.905	6.187
-122	1.030	1.312	-136	1.905	2.187	-150	2.780	3.062	-164	6.155	6.437
-123	1.093	1.375	-137	1.968	2.250	-151	2.905	3.187	-165	6.405	6.687
-124	1.155	1.437	-138	2.030	2.312	-152	3.155	3.437	-166	6.655	6.937
-125	1.218	1.500	-139	2.093	2.375	-153	3.405	3.687	-167	6.905	7.187

Not all of the standard dash numbers are listed. For additional sizes consult the factory. * See page 14 for E-gap recommendations

Gland Dimensions - Internal Face Seals

200 Series

Dash Size	Gland I.D.	Gland O.D.	Dash Size	Gland I.D.	Gland O.D.	Dash Size	Gland I.D.	Gland O.D.	Dash Size	Gland I.D.	Gland O.D.
-208	0.500	0.875	-222	1.375	1.750	-236	3.125	3.500	-250	4.875	5.250
-209	0.562	0.937	-223	1.500	1.875	-237	3.250	3.625	-252	5.125	5.500
-210	0.625	1.000	-224	1.625	2.000	-238	3.375	3.750	-254	5.375	5.750
-211	0.687	1.062	-225	1.750	2.125	-239	3.500	3.875	-256	5.625	6.000
-212	0.750	1.125	-226	1.875	2.250	-240	3.625	4.000	-258	5.875	6.250
-213	0.812	1.187	-227	2.000	2.375	-241	3.750	4.125	-260	6.375	6.750
-214	0.875	1.250	-228	2.125	2.500	-242	3.875	4.250	-262	6.875	7.250
-215	0.937	1.312	-229	2.250	2.625	-243	4.000	4.375	-264	7.375	7.750
-216	1.000	1.375	-230	2.375	2.750	-244	4.125	4.500	-266	7.875	8.250
-217	1.062	1.437	-231	2.500	2.875	-245	4.250	4.625	-268	8.375	8.750
-218	1.125	1.500	-232	2.625	3.000	-246	4.375	4.750	-270	8.875	9.250
-219	1.187	1.562	-233	2.750	3.125	-247	4.500	4.875	-272	9.375	9.750
-220	1.250	1.625	-234	2.875	3.250	-248	4.625	5.000			
-221	1.312	1.687	-235	3.000	3.375	-249	4.750	5.125			

300 Series

Dash Size	Gland I.D.	Gland O.D.	Dash Size	Gland I.D.	Gland O.D.	Dash Size	Gland I.D.	Gland O.D.	Dash Size	Gland I.D.	Gland O.D.
-316	0.687	1.250	-330	1.937	2.500	-344	3.687	4.250	-358	5.437	6.000
-317	0.750	1.312	-331	2.062	2.625	-345	3.812	4.375	-359	5.562	6.125
-318	0.812	1.375	-332	2.187	2.750	-346	3.937	4.500	-360	5.687	6.250
-319	0.875	1.437	-333	2.312	2.875	-347	4.062	4.625	-361	5.812	6.375
-320	0.937	1.500	-334	2.437	3.000	-348	4.187	4.750	-362	6.062	6.625
-321	1.000	1.562	-335	2.562	3.125	-349	4.312	4.875	-363	6.312	6.875
-322	1.062	1.625	-336	2.687	3.250	-350	4.437	5.000	-365	6.812	7.375
-323	1.125	1.687	-337	2.812	3.375	-351	4.562	5.125	-367	7.312	7.875
-324	1.187	1.750	-338	2.937	3.500	-352	4.687	5.250	-369	7.812	8.375
-325	1.312	1.875	-339	3.062	3.625	-353	4.812	5.375	-371	8.312	8.875
-326	1.437	2.000	-340	3.187	3.750	-354	4.937	5.500	-373	8.812	9.375
-327	1.562	2.125	-341	3.312	3.875	-355	5.062	5.625	-375	9.312	9.875
-328	1.687	2.250	-342	3.437	4.000	-356	5.187	5.750			
-329	1.812	2.375	-343	3.562	4.125	-357	5.312	5.875			

400 Series

Dash Size	Gland I.D.	Gland O.D.	Dash Size	Gland I.D.	Gland O.D.	Dash Size	Gland I.D.	Gland O.D.	Dash Size	Gland I.D.	Gland O.D.
-401	1.250	2.000	-413	2.750	3.500	-425	4.250	5.000	-437	5.750	6.500
-402	1.375	2.125	-414	2.875	3.625	-426	4.375	5.125	-438	6.000	6.750
-403	1.500	2.250	-415	3.000	3.750	-427	4.500	5.250	-439	6.250	7.000
-404	1.625	2.375	-416	3.125	3.875	-428	4.625	5.375	-440	6.500	7.250
-405	1.750	2.500	-417	3.250	4.000	-429	4.750	5.500	-441	6.750	7.500
-406	1.875	2.625	-418	3.375	4.125	-430	4.875	5.625	-442	7.000	7.750
-407	2.000	2.750	-419	3.500	4.250	-431	5.000	5.750	-443	7.250	8.000
-408	2.125	2.875	-420	3.625	4.375	-432	5.125	5.875	-444	7.500	8.250
-409	2.250	3.000	-421	3.750	4.500	-433	5.250	6.000	-445	7.750	8.500
-410	2.375	3.125	-422	3.875	4.625	-434	5.375	6.125	-446	8.250	9.000
-411	2.500	3.250	-423	4.000	4.750	-435	5.500	6.250	-447	8.750	9.500
-412	2.625	3.375	-424	4.125	4.875	-436	5.625	6.375	-448	9.250	10.000

Not all of the standard dash numbers are listed. For additional sizes consult the factory.

Gland Dimensions - External Face Seals

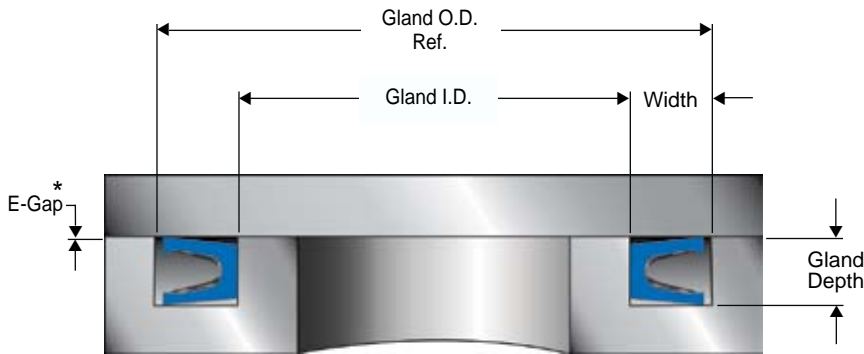

Gland Tolerances

Gland I.D.	Tolerance
0.125 - 2.999	+0.000 -0.002
3.000 - 7.999	+0.000 -0.003
8.000 and Up	+0.000 -0.004

Series	Width Min.	Gland Depth
-000	0.094	.057 - .059
-100	0.141	.089 - .091
-200	0.188	.121 - .123
-300	0.281	.186 - .188
-400	0.375	.238 - .241

000 Series

Dash Size	Gland I.D.	Gland O.D.	Dash Size	Gland I.D.	Gland O.D.	Dash Size	Gland I.D.	Gland O.D.	Dash Size	Gland I.D.	Gland O.D.
-006	0.125	0.312	-016	0.625	0.812	-026	1.250	1.437	-036	2.375	2.562
-007	0.156	0.343	-017	0.687	0.875	-027	1.312	1.500	-037	2.500	2.687
-008	0.187	0.375	-018	0.750	0.937	-028	1.375	1.562	-038	2.625	2.812
-009	0.218	0.405	-019	0.812	1.000	-029	1.500	1.687	-039	2.750	2.937
-010	0.250	0.437	-020	0.875	1.062	-030	1.625	1.812	-040	2.875	3.062
-011	0.312	0.500	-021	0.937	1.125	-031	1.750	1.937	-041	3.000	3.187
-012	0.375	0.562	-022	1.000	1.187	-032	1.875	2.062	-042	3.250	3.437
-013	0.437	0.625	-023	1.062	1.250	-033	2.000	2.187	-043	3.500	3.687
-014	0.500	0.687	-024	1.125	1.312	-034	2.125	2.312	-044	3.750	3.937
-015	0.562	0.750	-025	1.187	1.375	-035	2.250	2.437	-045	4.000	4.187

100 Series

Dash Size	Gland I.D.	Gland O.D.	Dash Size	Gland I.D.	Gland O.D.	Dash Size	Gland I.D.	Gland O.D.	Dash Size	Gland I.D.	Gland O.D.
-110	0.375	0.657	-124	1.250	1.532	-138	2.125	2.407	-152	3.250	3.532
-111	0.437	0.719	-125	1.312	1.594	-139	2.187	2.469	-153	3.500	3.782
-112	0.500	0.782	-126	1.375	1.657	-140	2.250	2.532	-154	3.750	4.032
-113	0.562	0.844	-127	1.437	1.719	-141	2.312	2.594	-155	4.000	4.282
-114	0.625	0.907	-128	1.500	1.782	-142	2.375	2.657	-156	4.250	4.532
-115	0.687	0.969	-129	1.562	1.844	-143	2.437	2.719	-157	4.500	4.782
-116	0.750	1.032	-130	1.625	1.907	-144	2.500	2.782	-158	4.750	5.032
-117	0.812	1.094	-131	1.687	1.969	-145	2.562	2.844	-159	5.000	5.282
-118	0.875	1.157	-132	1.750	2.032	-146	2.625	2.907	-160	5.250	5.532
-119	0.937	1.219	-133	1.812	2.094	-147	2.687	2.969	-161	5.500	5.782
-120	1.000	1.282	-134	1.875	2.157	-148	2.750	3.032	-162	5.750	6.032
-121	1.062	1.344	-135	1.937	2.219	-149	2.812	3.094	-163	6.000	6.282
-122	1.125	1.407	-136	2.000	2.282	-150	2.875	3.157	-164	6.250	6.532
-123	1.187	1.469	-137	2.062	2.344	-151	3.000	3.282	-165	6.500	6.782

Not all of the standard dash numbers are listed. For additional sizes consult the factory. * See page 14 for E-gap recommendations

Gland Dimensions - External Face Seals

200 Series

Dash Size	Gland I.D.	Gland O.D.	Dash Size	Gland I.D.	Gland O.D.	Dash Size	Gland I.D.	Gland O.D.	Dash Size	Gland I.D.	Gland O.D.
-208	0.625	1.000	-222	1.500	1.875	-236	3.250	3.625	250	5.000	5.375
-209	0.687	1.062	-223	1.625	2.000	-237	3.375	3.750	252	5.250	5.625
-210	0.750	1.125	-224	1.750	2.125	-238	3.500	3.875	254	5.500	5.875
-211	0.812	1.187	-225	1.875	2.250	-239	3.625	4.000	256	5.750	6.125
-212	0.875	1.250	-226	2.000	2.375	-240	3.750	4.125	258	6.000	6.375
-213	0.937	1.312	-227	2.125	2.500	-241	3.875	4.250	260	6.500	6.875
-214	1.000	1.375	-228	2.250	2.625	-242	4.000	4.375	262	7.000	7.375
-215	1.062	1.437	-229	2.375	2.750	-243	4.125	4.500	264	7.500	7.875
-216	1.125	1.500	-230	2.500	2.875	-244	4.250	4.625	266	8.000	8.375
-217	1.187	1.562	-231	2.625	3.000	-245	4.375	4.750	268	8.500	8.875
-218	1.250	1.625	-232	2.750	3.125	-246	4.500	4.875	270	9.000	9.375
-219	1.312	1.687	-233	2.875	3.250	-247	4.625	5.000	272	9.500	9.875
-220	1.375	1.750	-234	3.000	3.375	-248	4.750	5.125			
-221	1.437	1.812	-235	3.125	3.500	-249	4.875	5.250			

300 Series

Dash Size	Gland I.D.	Gland O.D.	Dash Size	Gland I.D.	Gland O.D.	Dash Size	Gland I.D.	Gland O.D.	Dash Size	Gland I.D.	Gland O.D.
-316	0.875	1.437	-330	2.125	2.687	-344	3.875	4.437	-358	5.625	6.187
-317	0.937	1.500	-331	2.250	2.812	-345	4.000	4.562	-359	5.750	6.312
-318	1.000	1.562	-332	2.375	2.937	-346	4.125	4.687	-360	5.875	6.437
-319	1.062	1.625	-333	2.500	3.062	-347	4.250	4.812	-361	6.000	6.562
-320	1.125	1.687	-334	2.625	3.187	-348	4.375	4.937	-362	6.250	6.812
-321	1.187	1.750	-335	2.750	3.312	-349	4.500	5.062	-363	6.500	7.062
-322	1.250	1.812	-336	2.875	3.437	-350	4.625	5.187	-365	7.000	7.562
-323	1.312	1.875	-337	3.000	3.562	-351	4.750	5.312	-367	7.500	8.062
-324	1.375	1.937	-338	3.125	3.687	-352	4.875	5.437	-369	8.000	8.562
-325	1.500	2.062	-339	3.250	3.812	-353	5.000	5.562	-371	8.500	9.062
-326	1.625	2.187	-340	3.375	3.937	-354	5.125	5.687	-373	9.000	9.562
-327	1.750	2.312	-341	3.500	4.062	-355	5.250	5.812	-375	9.500	10.062
-328	1.875	2.437	-342	3.625	4.187	-356	5.375	5.937			
-329	2.000	2.562	-343	3.750	4.312	-357	5.500	6.062			

400 Series



Dash Size	Gland I.D.	Gland O.D.	Dash Size	Gland I.D.	Gland O.D.	Dash Size	Gland I.D.	Gland O.D.	Dash Size	Gland I.D.	Gland O.D.
-401	1.500	2.250	-413	3.000	3.750	-425	4.500	5.250	-437	6.000	6.750
-402	1.625	2.375	-414	3.125	3.875	-426	4.625	5.375	-438	6.250	7.000
-403	1.750	2.500	-415	3.250	4.000	-427	4.750	5.500	-439	6.500	7.250
-404	1.875	2.625	-416	3.375	4.125	-428	4.875	5.625	-440	6.750	7.500
-405	2.000	2.750	-417	3.500	4.250	-429	5.000	5.750	-441	7.000	7.750
-406	2.125	2.875	-418	3.625	4.375	-430	5.125	5.875	-442	7.250	8.000
-407	2.250	3.000	-419	3.750	4.500	-431	5.250	6.000	-443	7.500	8.250
-408	2.375	3.125	-420	3.875	4.625	-432	5.375	6.125	-444	7.750	8.500
-409	2.500	3.250	-421	4.000	4.750	-433	5.500	6.250	-445	8.000	8.750
-410	2.625	3.375	-422	4.125	4.875	-434	5.625	6.375	-446	8.500	9.250
-411	2.750	3.500	-423	4.250	5.000	-435	5.750	6.500	-447	9.000	9.750
-412	2.875	3.625	-424	4.375	5.125	-436	5.875	6.625	-448	9.500	10.250

Not all of the standard dash numbers are listed. For additional sizes, consult the factory.

Technical Action Request

Date	Request	Eriks		 www.eriksusa.com	Name		
Market	Project				Company		
Equipment	Part Number/Description				Street		
Target Life	Product Code	I.D.	O.D.		CSD	City	ST
Quality Requirements	Compound	Polymer	Duro		Color	Tel	
Eriks Rep	\$	e.a.u.	Manufacturer		E-mail		

Fluid/Media		
Temp - Low	Temp - High	Unit °F / °C
Pressure - Average	Pressure - Peak	Unit psi / MPa / mTorr

<input type="checkbox"/> Reciprocating 	Stroke in. / mm.	Speed fpm/ mps
<input type="checkbox"/> Rotary 	Direction C.W. C.C.W.	Hz / rpm
<input type="checkbox"/> Other 	Runout In. / mm.	Misalignment in. / mm.
Other application comments:		

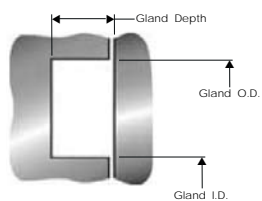
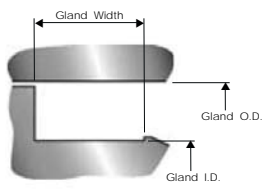
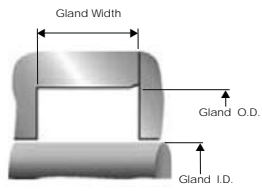
FACE	Description	Value	Unit
<input type="checkbox"/> INTERNAL <input type="checkbox"/> EXTERNAL 	Gland O.D.	±	in. / mm.
	Gland I.D.	±	
	Gland Depth	±	
	E-gap		
PISTON <input type="checkbox"/> 	Gland O.D.	±	in. / mm.
	Gland I.D.	±	
	Gland Width	±	
	E-gap		
<input type="checkbox"/> Open gland <input type="checkbox"/> Closed gland <input type="checkbox"/> Step gland			
ROD <input type="checkbox"/> 	Gland O.D.	±	in. / mm.
	Gland I.D.	±	
	Gland Width	±	
	E-gap		
<input type="checkbox"/> Open gland <input type="checkbox"/> Closed gland <input type="checkbox"/> Step gland			
BORE		SHAFT	
Material		Material	
Hardness	Rc/ ?	Hardness	Rc/ ?
Finish RA	µin/µm	Finish RA	µin/µm

Provide your own sketch

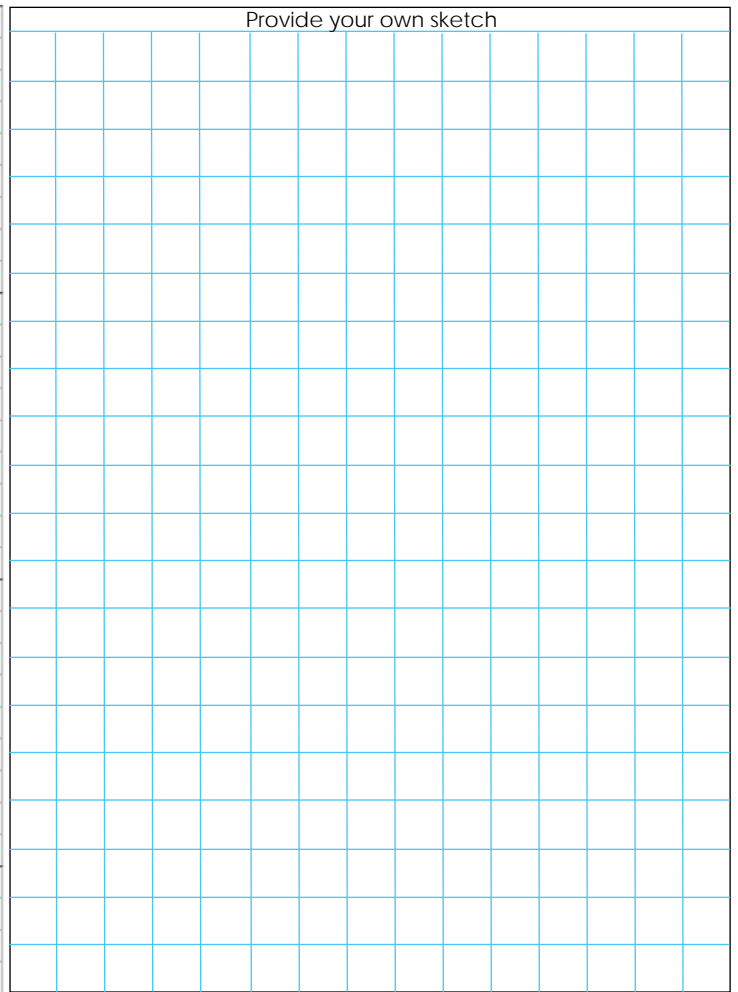

ERIKS worldwide

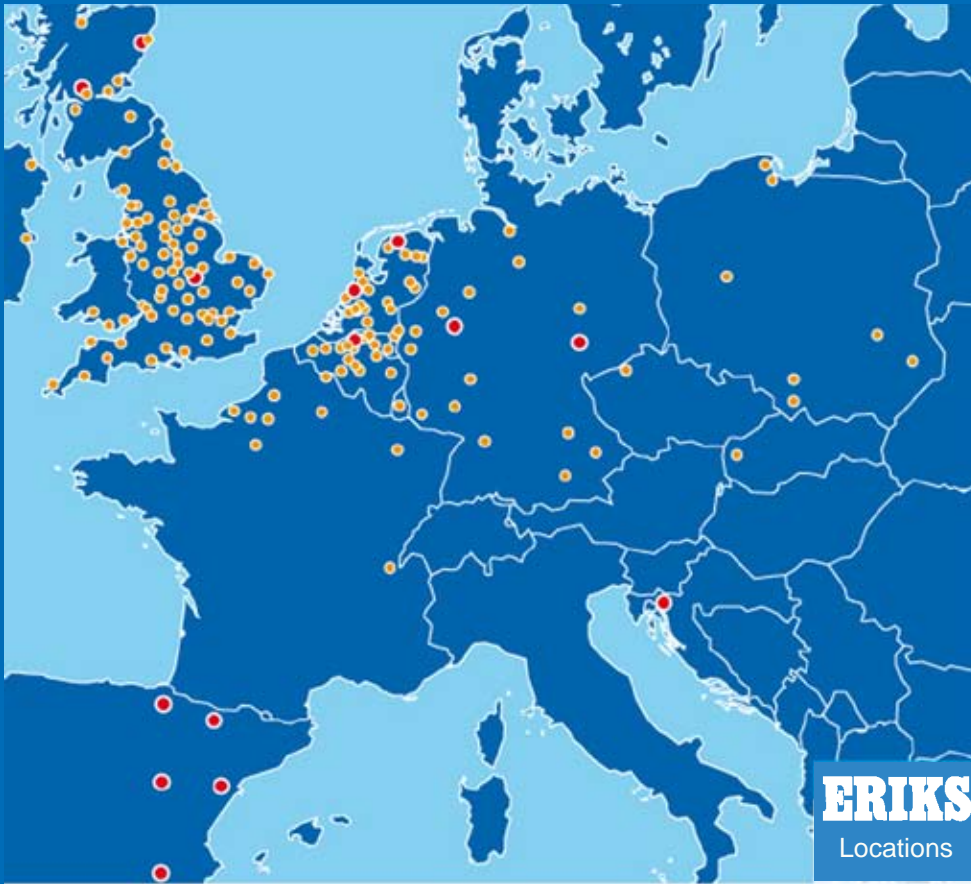

ERIKS USA

15600 Trinity Blvd., Suite 100
Ft. Worth, TX 76155
Tel: 682.292.5060
Fax: 817.571.4700

ERIKS Midwest

5330 South Emmer Drive
New Berlin, WI 53151
Tel: 262.785.1333
Fax: 262.780.3776

ERIKS Southwest

15600 Trinity Blvd., Suite 100
Ft. Worth, TX 76155
Tel: 682.292.5060
Fax: 817.571.4700

ERIKS West

14600 Interurban Ave. South
Seattle, WA 98168
Tel: 800.634.3417
Fax: 206.243.4718

1166 Knollwood Circle
Anaheim, CA 92801
Tel: 714.826.2000
Fax: 714.826.2001

Turpen & Associates

11815 East Apache St.
Tulsa, OK 74116
Tel: 918.665.0044
Fax: 918.665.0007

www.eriksusa.com

